

INTERNATIONAL RULES OF STICK-PULLING

GENERAL PROVISIONS

These rules of Stick-pulling (hereinafter – Rules) are the obligatory for all the organizations holding international Stick-pulling competitions.

Organizers of the competitions, representatives of the national teams, coaches, athletes, referees, participating in the competitions to be guided by these Rules.

CHAPTER I. FORMAT AND METHODS OF COMPETITION

Article 1. Format of the competition

1. Format of the competition is divided into: - individual; - team; - individual-team.
2. The format of the competitions is determined by the Regulations (Statement) of the competitions (hereinafter – Regulations).
3. In individual format only individual results are determined and places of participants in their weight categories.
4. In team format the teams meet with each other and their places are determined according to the results of the matches.
5. In individual-team format place of the team is determined by the sum of individual results of the participants.
6. The scoring for team and individual-team championship is determined by the Regulations (Statement).

Article 2. System of competition

In accordance with the system of elimination of the participants the competitions are held by:

- System with elimination after 2 (two) losses;
- System of direct elimination with consolation matches with finalists;
- Round-robin system;
- System with elimination after 1 (one) loss.

Regardless of the system of competitions, with the number of participants less than 6 people in the weight category, competitions in this weight category are held in a circular system.

1. System with elimination after 2 (two) losses. Compilation of pairs in each weight category is determined in numeric order by the results of drawing. On this basis, the pair of first round matched up in the following order:

- athlete№ 1 meets with the athlete№ 2;
- athlete№ 3 – with the athlete№ 4;
- athlete№ 5 – with the athlete№ 6, etc.

In a case of odd number of athletes in the weight category athlete with the last number is still free (without opponent), and proceeds to the next round without winning points, and he will be the first in the table for the next round of compilation pairs. He keeps up his place as long as the other participant, who in turn free, will not take his place at the top.

For example, nine athletes in weight category of the second round is composed as follows: 9-1, 2-3, 4-5, 6-7, 8 – free.

In the second round by 6, 10, 14, 18, 22, 26, etc. athletes, two athletes do not to stay free, three athletes with the highest numbers and the fifth athlete from the bottom of the table are combined in pairs as follows: by 6 (six) athletes – 2-5, 4-6, by 10 (ten) athletes – 6-9, 8-10, etc.

In all cases, the compilation of pairs so that in one round does not have 2 (two) free athletes, and the same athlete was not free twice, if there are athletes, who have not been free.

If after round there are only two athletes, who have one loss or no losses, then the first place belongs to the athlete who wins a bout between them. Third place goes to the athlete with the highest score among the retired in the last round of athletes.

If two athletes have the same points, the third place awarded to the winner of their match. If they have not met each other before, they are given additional bout.

In a case if there are 3 (three) not eliminated athletes, who have not met with each other, the places determine by the result of their direct individual meetings: the victories of match with 2 (two) of them are summed and from this amount deducted number of defeated bouts in these matches, thus, a qualified indicator meetings contenders for first place is on. Athletes are placed according to the reducing quality of this indicator (the first place is awarded for those who have the greatest indicator of quality). Then, in the case of the same qualities – the number of points earned in all bouts, then – on the quality of all bouts, then – according to their lighter weight during weigh-in (according to weigh-in protocol), then if equality of weights on the protocol of weigh-in – additional 3 weigh-in is carried out, and who has lightest weight is given an advantage. If in additional weigh-in their weights are the same, the first place is awarded to the both of them, the third place is given to the next athlete.

The allocation of places from the 4th and then carried out with the round of elimination by the number of points.

In the case of equality of points of two or more athletes, their placing is determined by considering the following factors:

- By the victory in the mutual meeting/match (when determine the placing of two athletes);
- By the quality of all bouts;
- By lighter weight during the weigh-in.

Depending on the quality of victory the scoring of points goes as follow:

- 2:0 – the winner gains 2 points, loss – 0;
- 2:1 - the winner gains 2 points, loss – 1.

Protocol of competitions of system with elimination after two (2) losses – Attachment 1.

2. System of direct elimination with consolation matches with finalists

System of direct elimination with consolation matches with finalists is used for the athletes who lose to finalists, i.e. the athletes that compete for the 1st and 2nd places.

There is needed number of athletes to utilize the system of direct elimination, i.e. 4, 8, 16, 32, 64, etc. If there is not such number of athletes in any category, qualification matches (adduction round) should be held.

Qualification matches to bring the number of athletes to the multiple numbers is held at the beginning of competitions for the athletes at the bottom of the table (highest lot numbers).

Consolation matches begin the athletes, who lose in the first round, including the adduction round, against one of two finalists and completed by the losers in the semifinal by the system of direct elimination. Winners of two final consolation matches take the third place.

Competitions are held as following:

- Qualification matches (adduction round);
- Elimination matches;

- Consolation matches;
- Final matches.

All the matches in each weight category are held during 1 (one) day. If there are less than 6 (six) athletes in one weight category, round robin system should be used (each athlete against every other athlete). Protocol of competitions of the system of direct elimination with consolation matches with finalists with 22 athletes in one weight category – Attachment 2.

Qualification matches (adduction round)

To bring the number of athletes to the multiple number, to be able to utilize the direct elimination system (16 athletes), qualification matches need to be held.

For example, there are 6 (six) athletes more of the multiple number 16. Qualification matches should be held among the athletes pulled a number higher than 16 at the drawing, i.e. 17, 18, 19, 20, 21 and 22 and 6 (six) athletes pulled out the numbers lower 17, i.e. 16, 15, 14, 13, 12 and 11. According to the compilation of pairs there are following order of matches:

- № 11 against № 12
- № 13 against № 14
- № 15 against № 16
- № 17 against № 18
- № 19 against № 20
- № 21 against № 22

Winners of these 6 (six) qualification matches are included in the elimination matches of the competitions by direct elimination system.

Elimination matches

After qualification matches we have the multiple number 16 (sixteen) of athletes. In this number of athletes are the 10 (ten) athletes who did not participate in elimination matches having pulled out numbers from 1 to 10 and 6 (six) athletes who won the qualification matches. According to pairing principle first elimination match is held as following:

- № 1 against № 2
- № 3 against № 4
- № 5 against № 6
- № 7 against № 8
- № 9 against № 10
- Winner of match № 11-№ 12 against winner of match № 13-№ 14
- Winner of match № 15-№ 16 against winner of match № 17-№ 18
- Winner of match № 19-№ 20 against winner of match № 21-№ 22

As a result of elimination matches we have 2 (two) finalists. In our case, they are athletes № 5 and № 15.

Consolation matches

All athletes defeated by the 2 (two) finalists have right for consolation matches. Athletes defeated from the finalist № 5:

- № 6 (lose 1 round);
- № 8 (lose 2 round);
- № 4 (lose 3 round).

Athletes defeated from the finalist № 15:

- № 16 (lose qualification match)
- № 18 (lose 1 round)
- № 21 (lose 2 round)
- № 10 (lose 3 round)

Consolation matches begin the athletes defeated from the finalists at the early stage of competitions.

1 st consolation match:

№ 6 (defeated in 1 round) against № 8 (defeated in 2 round).

2 nd consolation match:

Winner of the first consolation match (№ 6) against № 4 (defeated in 3 round);

Athlete № 6 – winner of consolation group, defeated from the finalist № 5.

The same method of competition is used for the athletes defeated from the finalist № 15:

1 st consolation match:

№ 16 (defeated qualification match) against № 18 (defeated in 1 round).

2 nd consolation match: winner of the first consolation match (№16) against №21 (defeated in 2 round). 3 rd consolation match: winner of the second consolation match (№16) against №10 (defeated in 3 round).

Athlete № 16 – winner of the consolation group, defeated from the finalist №15.

2 (two) winners of two last consolation matches (№6 and №16) take the 3rd places.

Final

Both of finalists (№ 5 and № 15) compete for 1st and 2nd places.

3. Round-robin system According to this system, athlete or team compete with each athlete or team. Form of protocol: Protocol of competitions of round-robin system – Attachment 3.

4. System with elimination after 1 (one) loss Athlete eliminates after 1(one) loss. Use adduction (qualification) rounds when necessary.

5. The system with elimination after two defeats with the division into groups "A" and "B".

In the first round, pairs are drawn up according to the draw. Athletes who win their fights continue to compete in group “A” until reaching the final, the ones who lost continue to compete in group “B” and have the right to compete only for third place.

If there are two athletes in the group “B”, who previously met in group "A", then they are given a re-fight. All athletes who have lost twice are eliminated from the competition.

If there is an odd number of participants, the athlete with the last numbering for the draw during the competition becomes free in this round and in the next round of the competition rises to the top of the standings and competes from the red side of the platform.

CHAPTER II. PARTICIPANTS OF COMPETITION

Article 3. Age groups The competitors are divided into the following age groups:

1. Junior boys 12-13 years
2. Senior boys 14-15 years
3. Boys 16-17 years
4. Girls 16-17 years
5. Juniors 18-21 years
6. Juniors (girls) 18-21 years
7. Men 18 years and older

8. Women 18 years and older
9. Male veterans (Masters I) 40-49 years
10. Male veterans (Masters II) 50 years and older
11. Veterans Women 40 years and older

Athlete should be achieved the indicated age before the date of competitions.

Article 4. Sport disciplines (weight categories)

Stick-pulling competitions are held in accordance with sport disciplines (hereinafter – weight categories). Absolute championship can be held among men and women without dividing the athletes into weight categories. Minimum weight of athletes for these competitions is determined by the Regulations (Statement).

The competitors are divided into the following weight categories (kg):

Junior boys 12-13 years - 40 50 60 70 70+

Senior boys 14-15 years - 50 60 70 80 80+

Boys - 50 60 70 80 80+

Girls - 50 60 70 70+

Junior boys - 60 70 80 95 110 110+

Juniors (girls) – 50 60 70 80 80+

Men - 60 70 80 95 110 110+ Absolute

Women – 55 65 75 85 85+ Absolute

Veterans Man - 60 70 80 95 110 110+ Absolute

Veterans Women – 65 65+

National federations are allowed to enter intermediate weight categories in their national competitions, without subsequently entering international competitions.

Article 5. Equipment and personal attributes of athletes

1. Equipment of the competitors:

- boys, juniors and men – sport shorts for Stick-pulling (fitting tightly whole or free-breed) and sports jersey (T-shirt or a long-sleeve shirt), red or blue (according to drawing).

- girls, junior girls and women – sport shorts for Stick-pulling (fitting tightly whole or free-breed) and sports jersey (T-shirt or a long-sleeve shirt), red or blue (according to drawing). It is forbidden to combine blue and red colors of sports jersey (T-shirt or a long-sleeve shirt) and shorts.

- participants must compete in sports shoes without spikes with soft sole. Do not use shoes with heels, soles, nailed, with buckles or other metal, plastic and sharp items.

2. Color of an athlete's equipment must match the color of the side of platform on which he/she is invited – red or blue (according to drawing).

3. In order to prevent sports injuries, it is allowed to use the following personal attributes:

- Elastic bandages with width not exceeding 25 cm;

- Special belts with width not exceed 10 cm, the weight of the belt should not exceed 1,5 kg;

- Handhelds (palm pads) not exceeding the width and height of the athlete's palm. It is prohibited to use any liquid substances for processing handhelds;

- Knee and elbow pads with length no more than 30 cm.

- Sport taping;

- Supporting and fixing equipment;

- Grip aids without tacky composition in form of powder (magnesia, rosin), and liquid magnesia.

4. Forbidden go to the platform after calling to compete in jewelry, amulets, chains, bracelets, rings, earrings, watches, head-dress and form of clothing that is not comply with the Rules
5. If an athlete goes to the platform in not corresponding equipment, the Grand Jury gives him a maximum of 1 (one) minute to change clothing. If after this time an athlete does not in proper clothing, he is considered loss.
6. Coach going along with an athlete during the match, have to be in sports clothing with the symbol of the country represented by the athlete.

Article 6. Duties and rights of athletes

1. Athlete is obliged to:

- know and obey to rules, Regulations (Statement) and program of competition;
- follow directions given by referees;
- go to the platform in time by a call of the Grand Jury;
- be polite with respect to all the participants and spectators.

2. Athlete has right to:

- receive timely the necessary information of competitions, program of competition, changes in a program of competition;
- receive information of decisions by Grand Jury via official representative of his/her team.
- 2 (two) breaks to be provided for medical care with the duration up to 2 (two) minutes each break in one day of competition. Additional medical breaks are provided by decision of the arbitrator refereeing a match.

Article 7. Representatives of teams, coaches

1. Mediator between Grand Jury of the competition and athletes (coaches) of team is the team representative.

2. If a team does not have a representative, his duties carried by coach or team captain.

3. Representatives of the teams must be at the places specially designated for them.

4. The team representative cannot be a referee and a physician of the competitions at the same time.

5. The representative of the team performs the following functions:

- take part in the drawing process;
- take part in the joint meetings with the referees, where he/she can make comments on the work of referees only on the basis of specific provisions of the Rules of the competition, take part in approval of the results of each day and the competition in general;
- responsible for the discipline of the team members and ensures their timely attendance at the competition.

6. Team representative is forbidden to interfere in the decisions of referees and officials of the competition, as well as perform actions that offend the referees.

7. For violation or in observance of his responsibilities, representative of the team can be suspended from his duties until the end of the competition.

8. Coaches during a match:

- during a match, no more than 2 (two) coaches (seconds) can be on the athlete`s part;
- coaches (seconds) must wear a sportswear of the country he and the athlete represent;
- coaches (seconds) are allowed to assist doctor in providing medical assistance to his athlete;
- coaches (seconds) are prohibited to influence decisions or offend the referees;

In the case of non-compliance with these rules the arbitrator is obliged to ask the head of platform to make the remark to coach, if he/she keeps breaking the rules, then the head of platform removes

him from the competition. Thereafter, the coach cannot continue to perform his/her duties. But his/her athlete can use of services of other coach.

CHAPTER III. GRAND JURY

Article 8. Composition of Grand Jury

1. Competitions are conducted by the Grand Jury composed by: Chief Referee, Vice Chief Referee, Chief Secretary, head of platform, arbitrators (referee on the platform), side referees, referee-timekeeper, referee-secretaries, referee-expeditor, referees of athletes, referee-technical secretary.
2. Judging team on the platform consists of the head of platform, arbitrator, side referee, referee-secretaries, referee-technical secretary, referee-timekeeper and referee expeditor and referees of athletes.
3. The composition of Grand Jury for the competition shall be approved by the respective federation or organization holding the competition, based on the status of the competition, number of participants and number of platforms (Attachment 4, 5).
4. Referees should have corresponding qualification and authority, in accordance with these Rules.
5. Replacement of a member of judicial brigade on the platform during a match prohibited, except in cases:
 - injuries, confirmed by a doctor, not allowing him/her to perform his/her duties;
 - illness, confirmed by a doctor, not allowing him/her to perform his/her duties.

Article 9. Chief Referee

1. Chief Referee manages the competition in accordance with the competition Regulations and Rules. He/she is responsible for the competition to the Organization, conducting these competitions
2. Chief Referee has to:
 - check the readiness for the competition all lodgings, equipment, inventory, their compliance with requirements of the Rules to make the Act of receiving the competition venue (Attachment 6), and ensure the presence of all necessary documentation;
 - organize and supervise the weigh-in process;
 - organize and control the drawing process;
 - approve the schedule of the competition;
 - consider protests and to take decisions on them in timely fashion;
 - hold meetings of referees of the competition in conjunction with representatives of the teams before the competition, after each day of competition, as well as in cases when it is deemed necessary;
 - no later than 5 days after the end of the competition submit the report to the organization that held the event.
3. Chief Referee has the right to:
 - cancel or postpone the event, if at the beginning of an event the venue, equipment and facilities are not ready;
 - terminate or suspend the competition under adverse conditions (weather, public nuisance);
 - make an adjustment of the program and schedule of competitions;
 - make timely change of referees during the competition;

- stop the bout in case of a serious violation and ask the arbitrator, side-referee and the head of platform what motivated their decision. After the meeting with the arbitrator and the head of platform, he/she can change the decision (if the majority of the votes in his favor);
 - discharge referees who have committed serious errors and / or unable to cope with the duties;
 - remove from the competition participants committed gross violations of the Rules and flawed relationship to other participants, spectators and referees;
 - issue a warning or suspend from his/her duties representative (coach, captain), committed act of rudeness towards the referees or not fulfilling his/her duties.
4. Execution of orders of the Chief Referee is mandatory for referees, participants, representatives and coaches.
5. In the absence of the Chief Referee his duties are carried out by Vice Chief Referee.

Article 10. Chief Secretary

Chief Secretary:

- directs the work of the secretariat of competitions;
- is part of the Commission for the admission and provides the registration of participants;
- is part of the brigade of referees at weigh-in;
- organizes the drawing process;
- makes program and schedule of the competitions;
- makes the protocols of the competition;
- makes the order of matches of rounds;
- controls filling of bout protocols;
- prepares orders and decisions of the Chief Referee;
- presents to the Chief Referee the results of the competition for approval and the necessary data for the final report;
- provides information to representatives, commentators and journalists;
- makes a general technical report and after the approval of the Chief Referee, passes it to the organization that held the competition;
- provides informational materials all services of competitions, team representatives, media representatives;
- controls the process of installing and setting up computer network, computer hardware and software required for the work of the secretariat.

Article 11. Head of platform

1. Head of platform is responsible for the work of the judicial brigade on platform, directs the course of the match, controls that the match is conducted in accordance with 11 the Rules.

2. Head of platform shall:

- organize and coordinate the work of judicial brigade;
- evaluate the actions of participants;
- if during the bout the head of platform considers necessary to attract the arbitrator`s attention to anything (victory, prohibited technique, etc.) that has not been seen by arbitrator, head of platform has to say into the microphone, even if the arbitrator did not ask his opinion;
- if necessary to stop bout, match;
- make a final decision on the result of match, in case of disagreement between the arbitrator and side-referee;
- keep the Chief Referee or his/her vice informed on the competition on the platform.

3. Head of the platform has right to:

- interrupt the bout and stop the match;
- make proposals to the Chief Referee on the disqualification of a participant (athlete);
- evaluate the performance of each member of the judicial brigade;
- provide suggestions to Chief Referee for dismissal of referees, who have committed grave mistakes or failed to cope with their responsibilities;
- disallow participants or referees, whose appearance does not meet the requirements of the Rules;
- combine the duties of referee-timekeeper;
- attract the arbitrator`s attention to anything during the bout or in the behavior of the athletes seemed to him strange or incorrect.

4. The head of platform at the end of the bout should have the results in the report and sign it.

Article 12. Arbitrator (referee on the platform)

1. Arbitrator is responsible for the match on the platform in accordance with the Rules.

2. Arbitrator, while on the platform facing the main stand so as not to obscure the view of the side-referee, head of platform, Chief Referee, evaluates technical actions of athletes and ensures that the bout takes place in accordance with the Rules.

3. Arbitrator has to:

- check the inventory before the match;
- check the readiness of the participants to bout;
- comply with the requirements of the Rules for the bout, match;
- guide the course of the match, using gestures and commands of referee;
- correctly and timely evaluate the actions of athletes;
- issue warnings to athletes if necessary;
- explain for the request of the head of platform the reasons for his decisions;
- when declaring the result of the match to stand facing the main stand, take hands of both participants and raise the hand of the winner;
- require the athletes to stay on the platform until the declaration of results;
- in any case, requiring the approval, ask the opinion of the head of platform first;
- stop the bout if the head of the platform attracted his attention through a microphone;
- declare the winner after consulting with side-referee and the head of platform;
- ensure athletes shake hands with each other and arbitrator after the announcement of the result;
- punish the athlete for breaking the Rules or rude behavior.

4. Arbitrator stops the bout when:

- one of the participants is issued a warning;
- one of the participants is defeated;
- participant is injured or bleeding;
- required by the head of platform or Chief Referee.

5. Arbitrator should have complete control over the actions of the participants that they immediately followed his instructions and requirements.

6. Arbitrator should wear:

- Red band on his right wrist and blue band on his left wrist.
- White rubber (elastic) gloves while refereeing the match.

7. During the match arbitrator must use the following commands and gestures:

- whistle – call of athletes in the middle of the platform to start the bout;
- Sit down! – pull hands with palms down at level of shoulders and drop down;

- Ready!
- Go! (Start!) – at the same time with command sharply raise the palm of right hand between the participants over the stick;
- “Stop!” and/or whistle – stop the bout.
 - First warning: stops the bout by whistle or command “Stop!”, touches with his hand the shoulder who gained a warning, raise the thumb upwards, the other fingers should be clenched in a fist, reach out to the side warning-gained athlete and says “first warning!”;
 - second warning: stops the bout by whistle or command “Stop!”, touches with his hand the shoulder who gained a warning, show thumb and index fingers with outstretched arm to the side of warned athlete and stops the bout with command “second warning” and reach out with an open hand to the side of the winner;
 - disputed provision – two thumbs to show up in front of himself, the remained fingers clenched into a fist;
 - victory in a bout – pulls hand with open palm toward the winner.

Article 13. Side-referee

Side-referee is located in opposite of arbitrator so that the area of platform is in a good view and evaluates the technical actions of participants.

Side-referee has to:

- evaluate the actions of competitors correctly;
- express his opinion, using gestures of the arbitrator;
- if necessary, without entering the platform take more comfortable position or location;
- if necessary, explain to the head of platform and to arbitrator the reasons for his decisions.

Article 14. Referee-technical Secretary

Referee-technical secretary sits at the table of the head of platform and in the course of each match by technical means shall show the names of participants, as well as assessments and penalties after the arbitrator declared them. In case of absence or failure of an electronic scoreboard, assessments and penalties are shown on the hand-operated mechanical scoreboard. He/she fills the required areas of the referee’s protocol (assessment, time of bout, quality of victories etc.), and after the end of each bout score sheet is transferred to the secretariat.

Article 15. Referee-timekeeper

Referee-timekeeper is located at the table of the head of platform and provides timekeeping in accordance with the following points of the competition:

- keeps the time at 1 minute after the official call of an athlete during which the athlete should appear on the platform;
- keeps the time at 2 minutes for a bout;
- keeps the time at 30 seconds after “Sit down!” before a bout;
- keeps the time at 1 minute before 2nd and 3rd bouts;
- keeps the time at 30 seconds at the declaration of the disputed provisions by arbitrator;
- keeps the time at 2 minutes for breaks by medical reasons. An athlete has right for 2 (two) breaks by medical reasons in one day of a competition. Additional medical breaks can be provided by decision of the arbitrator refereeing a match.

Referee-timekeeper shall inform the head of platform and arbitrator about violation of the time limits of the competition.

Article 16. Referee-expeditor

Referee-expeditor:

- responsible for informing the participants and referees in time;
- calls athletes to the platform;
- announces the next couple of athletes;
- announces the result of the finished bout;
- speaks issuing cautions and disputed provision (“... the first warning”, “... a second warning”, “disputed”);
- making announcements by indication of the Chief Referee and Vice Chief Referee;
- informs of the athletes’ sport results as soon as possible;
- announces changes in the program and the conditions of the competition.

Article 17. Referees of participants

Referees of participants must perform the following functions:

- check before each match the presence of athletes and in case of absence, report to the head of platform;
- familiarizes athletes with their sequence going on the platform;
- check compliance of equipment in accordance with the rules of competition;
- accompanies athletes to the platform and back after match;
- accompanies to the zone of the doping control those athletes determined by Doping Control Service;
- check the presence and accompanies the athletes to the victory zone for awarding procedure of athletes – the winners of the competition.

Article 18. Physician

Physician of competition is a part of the Grand Jury on the rights of the Vice Chief Referee for the medical part and takes part in its work.

Physician:

- part of the Commission for acceptance of the competition venues;
- checks the correctness of applications;
- present at the weigh-in, carry out physical examination of the athletes;
- has right to stop the bout at any time, reporting the necessarily to the head of platform if he/she considers that one of the athletes needs medical care.
- has the right to forbid the athlete further participation in the competition because of injury or disease (writing prohibition to the secretariat of competition should be given, and the athlete disqualified);
- after the competition submits the report to the Chief Referee on medical and sanitary provision of the competition with indication of injuries and illness.

Article 19. Commandant

1. Commandant is responsible for the timely preparation and solemn decoration of competition venues, security, accommodation and service of participants and spectators, installation of wired radio, maintenance of order during the competition and provides all the necessary activities by the instructions of the Chief Referee.

2. Commandant is responsible for the preparation and suitability for the use of special equipment and tools for the competition in accordance with the Rules.

Article 20. Uniform of referees

The members of the Grand Jury during the performance of their duties must wear uniform of referees:

- Chief Referee, Chief Secretary, heads of platform, referees-secretaries, referee-timekeepers – black jacket, white shirt, red tie and black pants;
- arbitrators, side-referee – white short-sleeved shirt, white pants, and white rubber-soled shoes. Arbitrators and side-referees must have a whistle.

The members of the Grand Jury are not allowed to have on clothes and shoes with logo or name of the sponsor.

Article 21. Sanctions imposed on referees

In case of violation of rules by a referee the Chief Referee has right to apply to referee (referees) the following disciplinary actions:

- issue a warning;
- remove from the refereeing of competition.

CHAPTER IV. COMPETITION PROCEDURE

Article 22 Weigh-in

1. Weigh-in procedure establishes correspondence of weight of an athlete within one of the weight categories. The athlete has right to participate in the competitions only in the weight category that is set for him/her at weigh-in.
2. Order and time of weigh-in is indicated in the Regulations of the competition. The athlete who is late or did not come to weigh-in is not allowed to take part in the competition.
3. Weigh-in procedure is conducted by Vice Chief Referee, referee of participants, referee-secretary appointed by the Chief Referee.
4. Within 30 minutes before official weigh-in, participants are given the chance to control their weight on scales on which the official weigh-in will be held.
5. At any competitions weigh-in is carried out by weight categories or teams.
6. Before weigh-in all the participants pass physical medical examination by physician of competition. The athlete will not be allowed to weigh-in, if he/she has not passed the medical examination.
7. At weigh-in the athlete must provide a document proving his/her identity.
8. Weigh-in of the participants is carried in a specially designated and equipped place. Participants are weighed in equipment for Mas-Wrestling (without shoes), prescribed in these rules. It is not allowed to proceed to weigh-in without the equipment.
9. Reweigh-in of participant is allowed before the end of weigh-in procedure if his/her weight does not fit the applied weight category.
10. Weigh-in results are recorded in a protocol and signed by the members of weigh-in commission (Attachment 7).

Article 23 Drawing of lot numbers

1. Before starting the competition, participants are divided into pairs according to numbers obtained by drawing during the weigh-in procedure.
2. The drawing shall be held in public. Numbered tokens, the number of which equals the number of participants that have passed a medical examination, put in the ballot box, a bag or other similar object.

3. An athlete weighs-in, and thereafter pulls a lot number which will be used drawing up of pairs. This number is recorded in starting protocol and protocol of weighing.

Article 24 Compilation of pairs

Compilation of pairs (matches) is based on the system of the competition, which is registered in the Regulations (Statement) of the competitions, with lot numbers drawn at weigh-in.

CHAPTER V. MATCH

Article 25 Call and presentation of athletes

1. Referee-expeditor calls athletes to the platform to begin the match. The athlete should go out on the platform after official call before the expiration of 1 (one) minute. If the athlete does not go to the platform within one 1 (minute), he/she will be disqualified and does not award any place. His/her opponent is declared the winner of the match.
2. The athlete cannot be called to compete in a new match, if there is less than 15 minutes since the end of the previous match in which he/she competed.

Article 26. Beginning, going and end of the match

1. Match consists of 2 or 3 bouts (up to two victories).
2. The athlete, who was invited first, must take the platform side, marked in red, to the right of the arbitrator and the second athlete – to the side marked in blue, to the left of the arbitrator. Stepping onto the platform, the athletes are required to salute each other by hand shaking.
3. After the greeting for the beginning of the bout, before the first bout athletes are given time to prepare, but no more than 1 (one) minute before the command “Sit”). Upon command of the arbitrator “Sit!” athletes sit opposite each other in middle of the jamb board, their feet abut on the jamb board inside the marked start zone, heels should touch the platform and grip the stick, the heels and the pelvis (buttocks) of an athlete should not raise over the platform.
4. The athlete came out from a red corner chooses the gripping position of the stick (internal or external). Grips must be traditional (i.e. left grip – left hand is palm down and his right hand palm down) and has no right to change it (unsymmetrical).
5. The athlete, who took internal grip, grabs the stick first in the middle so as to leave space for external grip and holds a stick over the board. The second athlete grabs the outside. Hands and fingers do not have to overlap each other, distance between the hands should be 1 cm.
6. Wrists and forearms must be aligned (straight).
7. After making the grip athletes should not let it go. The athlete released the stick first before the command of the arbitrator, takes a warning.
8. Stick before the match should be located above jamb board and in parallel with it. Deviation in any direction of ends of the stick about the longitudinal axis of the board to 5 cm is allowed, the center of the stick must be above board.
9. After “Sit down!” till “Ready” is given no more than 30 seconds. If after expiration of this time the start signal was not given, then the arbitrator gives a warning to the athlete whose fault caused delay.
10. After the command "Ready!", The athlete is obliged to stop any movement and take a static position until the command "Go(Start)!" Bout begins after the arbitrator`s command “Go!”. Pause between “Ready!” and “Go!” should be 1 – 1.5 seconds.

11. In case of the victory one of the athletes the arbitrator stops the bout by whistling or commanding “Stop!” and reaches out with open hand to the side of the winner.
12. In case of the disputed/controversial provisions, the arbitrator stops the bout by whistling or commanding “Stop!” and two his thumbs up in front of himself, the other fingers clenched into a fist. Competitors are given an additional bout and the grip of the stick remains the same.
13. If during the match one of the athletes received second warning, the arbitrator touches the shoulder who took the warning, shows by the thumb and index fingers, arm outstretched towards the participant who took warning and commands: “Stop!” or whistling and pull the open palm hand in the direction of the winner.
14. The duration of a bout no more than 2 (two) minutes, if after this time, there is no winner, both participants lose the match with the score 0:2.
15. The athlete came from blue side chooses the grip in the second bout.
16. Between bouts athletes are given time no more than 1 (one) minutes for preparation.
17. In case of score 1-1, before the 3rd bout should be conducted drawing by throwing-in a two-colored cube. The grip (internal or external) chooses the athlete who won the toss.
18. During the match, the participant has no right to leave the competitive side and technical zone without the arbitrator's permission. The athlete has right to take 2 (two) breaks (time-out) with the duration no more than 2 (two) minutes during a day of competition for medical care with the arbitrator's permission. If after break, the athlete cannot continue the interrupted match, he/she loses the match. At the discretion of the arbitrator, refereeing the match, the athlete may be given additional breaks for medical reasons.
19. At the end of the match arbitrator stands in front of spectators, face-to audience for the declaration of the winner, the participants stand on both sides of the arbitrator. After the announcement of the results, the arbitrator raises the hand of the winner, then athletes must shake hands with each other and the opponent's second.

Article 27 Interrupting the match

1. If necessary, the right to interrupt the match have: The Chief Referee, the head of the platform or the arbitrator of the match
2. If the match cannot be continued for medical reasons, the decision is made by a physician, who informs the coach of an athlete and the head of platform, who stops the match.
3. The head of platform can interrupt the bout due to serious mistake made by the arbitrator. He/she also can interrupt the bout due to a serious mistake in assessment of actions by the arbitrator or side-referee. In such cases, he/she shall hold consultations. If the head of platform does not agree with them, he/she must watch the episode on videorecorder and give the final decision. In no case can an athlete interrupt the bout himself.
4. If the bout is stopped due to intentional injury of an athlete by his/her opponent, the perpetrator athlete will be disqualified and the injured athlete – declared the winner.

Article 28 Number of matches

If the competition is going 1 (one) day, the number of matches for one athlete should not exceed 6 (six) matches. If the event lasts more than 1 (one) day, the number of matches per day for 1 (one) athlete should not exceed 5 (five) matches per day.

CHAPTER VI. ASSESSMENT OF METHODS AND ACTIONS

Article 29 Assessment of methods and actions

The head of platform and side-referee evaluate the actions of participants during a match. In case of disagreement of referees in determining the winner, the head of platform or the Chief Referee issue the decision.

29.1 Prohibited acts and methods After “Sit down!” and till the end of the bout athletes are prohibited to:

- talk to each other;
- talk and argue with the arbitrator;
- talk to the coach;
- touch the opponent's arm;
- pull sharply and (or) to push the stick before the start, i.e. before “Go!”;
- hold the stick on one`s side concerning the board before start;
- capture and twist the stick before start; - hook on and abut stick and/or hands on the board and/or toe;
- abut by legs, touch by torso or head on side supports;
- intentionally twist the stick more than 90 degrees in all directions to the longitudinal axis of the board; - overstep the start zone on the board before the start;
- tear the heel away the platform before the arbitrator`s command "Go!".

29.2. Warning for violation of the Rules

The arbitrator makes a warning without asking permission from members of the Grand Jury.

Warning is declared:

- for using of prohibited act or method;
- first who released his grip before the arbitrator`s command “Go!”;
- if the victory achieved by using of prohibited act or method, the athlete who used the prohibited act or method is given a warning, the victory does not count and the bout resumed.
- an athlete is disqualified for breach of discipline, rude violation of the Rules.

29.3. Suspension of an athlete from the competition

Athlete is suspended from the participation in competition if:

1. Athlete did not come onto the platform during 1 (one) minute after invitation for the match without medical reasons and not informing the secretariat.
2. According to the conclusion of a physician for getting injury or illness.
3. Unsportsmanlike behavior:
 - use of expletives;
 - menace, abuse of opponent or referees;
 - aggressive behavior;
 - striking a blow;
 - intentional violation of Rules;
 - unethical or rude behavior to the referee or opponent and other official representatives of the Federation.
4. Alcohol consumption and/or narcotics and/or psychotropic substance while participation in the competitions.
5. Bleeding of palms or hands (tearing off the calluses, open wounds) and not using of palm pads or bandage to prevent bleeding.

6. Forbidden go to the platform after calling to compete in jewelry, amulets, chains, bracelets, rings, earrings, watches, head-dress and form of clothing that is not comply with the Rules in case of refusal of the participant to comply with these Rules, he / she will be removed from the competition.

29.4 Determination of the winner in the bout and match

1. Victory in the bout is awarded to the athlete if:

- pulled stick out of the opponent`s hands;
- pulled the opponent over the board with stick;
- opponent picked both feet off the board;
- opponent took the second warning in the bout;
- opponent moved one foot across the board and touched the platform or opponent; - opponent released his hand from the stick;
- opponent touched the board and/or side support by his body and/or head, knee, hip;
- opponent abut by foot on the side support (stepped on the side support).

2. Victory in the match is awarded to the athlete who wins 2 (two) bouts.

29.5 Controversial/Disputed provision

Controversial/Disputed provision is declared if:

- opponents fell down at the same time and cannot continue the bout;
- break a stick;
- opponents released the stick at the same time;
- creeping of hands onto each other during the bout.

CHAPTER VII. PROTEST

Article 30 Protest

1. The protest can be submitted by the representative of the team (coach) for breach of the rules of refereeing during the bout in his opinion.

2. The procedure for filing a protest:

- a protest given by throwing a cube on a competitive platform by the representative (coach) the team at the end of the bout, in which he detected the breach;
- before the consideration of the controversial issues, within 5 minutes after the throw a cube, protest must be submitted in written form on the official form indicating breach (Attachment 8);
- when submitting the protest, a sum of money, determined by the Regulations (Statement) of competition should be paid.

3. Consideration of the protest:

- in the case of a protest on breach of the rules in refereeing the bout, it is considered by the Chief Referee with the assistance of referees` brigade involved in the refereeing of the bout, as well as representatives of the parties (without the right to discuss the protest);

4. The decision on the protest is taken immediately after the discussion of the situation. Chief Referee informs concerned parties of the taken decision, and then the match continues.

- in case of the protest is upheld, sum of money should be refunded.

CHAPTER VIII. INVENTORY OF THE COMPETITION VENUES

Article 31 Competition area

Area for competition should be a raised platform – smooth, without rough area, capable of supporting loads of up to 600 kg/m², sized 600 cm x 600 cm; height 20 – 100 cm and technical zone with the dimensions 1.5 – 2 m from the blue and red sides of the end of the platform (Attachment 15).

Working area of the platform has sizes – 200 cm x 400 cm should be covered with a material with a smooth surface (fiberboard, wooden fiberboard, smooth canvas etc.).

Article 32. Jamb board and stick

1. The board should have the following dimensions:

- for men and women: length of the inside is 120 cm (between the side supports), height – 24 cm, width – 4-6 cm, edges of the upper edges should be rounded, smooth, height of the rounded top edge – 1.5 cm;

- for boys and girls: length of the inside part is 120 cm (between the side supports), height – 22 cm, width – 4-6 cm, the edges of the upper edges should be rounded, smooth, height of the rounded top edge – 1.5 cm (Attachment 16).

1.1. Board must have start zone marked contrast lines, spaced from the outer edges of the board to 10 cm.

1.2. The board should be firmly secured at both ends with side supports with width 15 – 25 cm, height of 22-24 cm.

Side supports should be smooth, without sharp angles (Attachment 17).

2. The stick should be made from birch or other durable species of wood, the stick should have center mark with width in 1 (one) cm with following dimensions: length 40- 50 cm, diameter 34 mm (+,- 1 mm), center mark 10 mm (Attachment 17).

3. In all official competitions the inventory must be certified by the WSF.

Article 33 Judicial and informational equipment

Informational table

Informational table (for each platform) should be located beyond of working zone, that the information can be seen for referees, spectators, officials. The table should show the match (results, warnings, etc.).

Video system

Video system should be used for the referees as additional help, recording the bout.

CHAPTER IX. INTERPRETATION OF THE RULES

Article 34 Amendments to the Rules and unforeseen events

The Council of the WSF has the exclusive right to interpret the Rules of interpretation of certain articles. In case of litigation legal effect has only Russian text of the Rules.

National Federations can translate the Rules in their official language.

Protocol of the competition by the system with elimination after 2 (two) losses

_____ (competition)

Competition venue _____

“ _____ ” _____ 201__

Weight category _____ kg

Drawing number	Name	Team	Date of birth	Rounds						Elimination round	Points	Place

Chief Referee:

Chief Secretary:

An example of competitions by the system of direct elimination with consolation matches with finalists (22 athletes)



Consolation matches

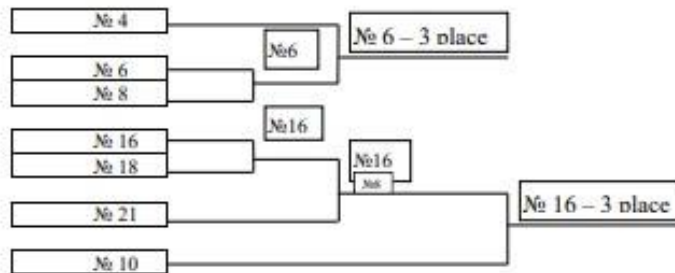

Round-robin system protocol

 (competition)

Competition venue _____

“ ” _____ 201 ____

Weight category _____ kg

№	Name	Team	Score	Score	Score	Score	Victory	Score	Place
1									
2									
3									
4									

Chief Referee:

Chief Secretary:

Chief Referee

(competition)

(Name of Chief Referee)

Protest

Team _____

Submit a protest to the match between _____

Detailed description of the circumstances related to the violation of the competition rules
(reasons)

« _____ » 20__ г.

(Position)

(Signature)

_____ / _____ /

(Print full name)

Platform with the board

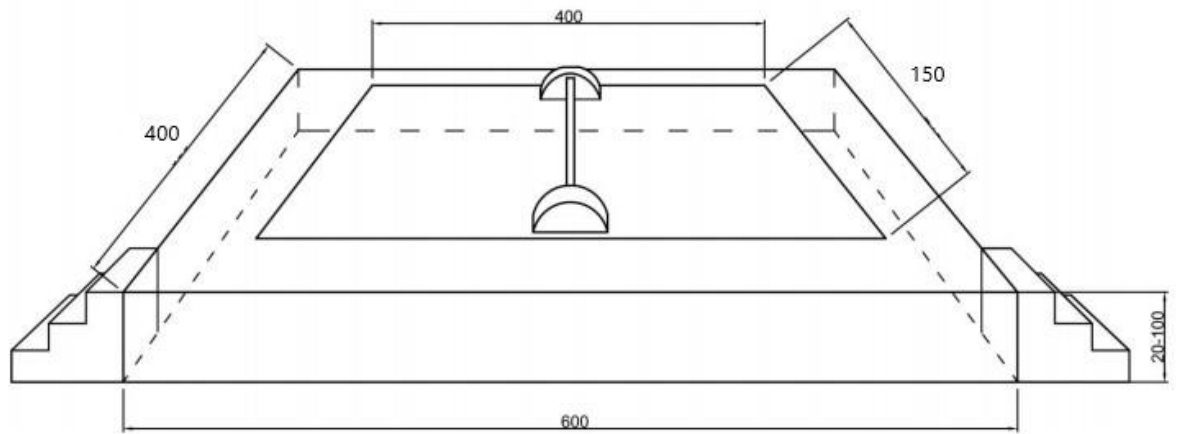

Jamb Board for boys and girls

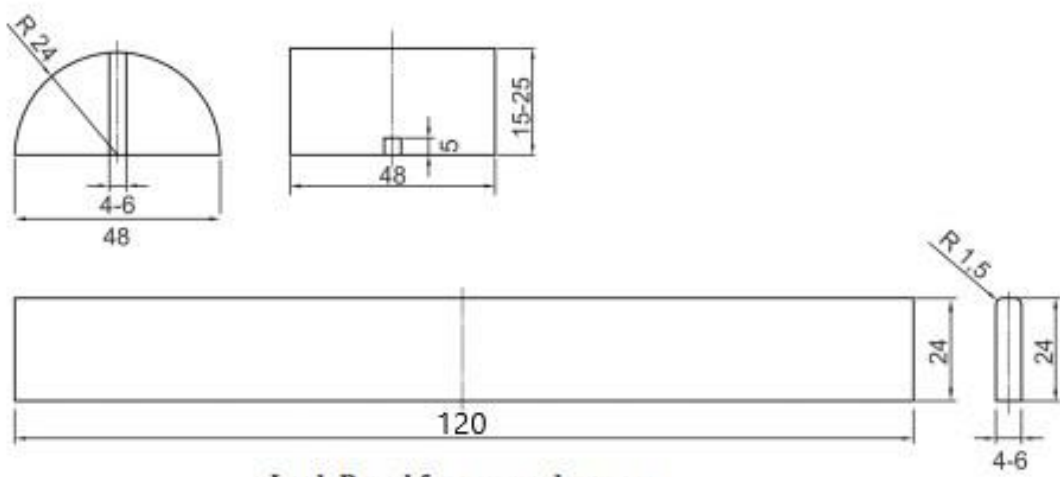
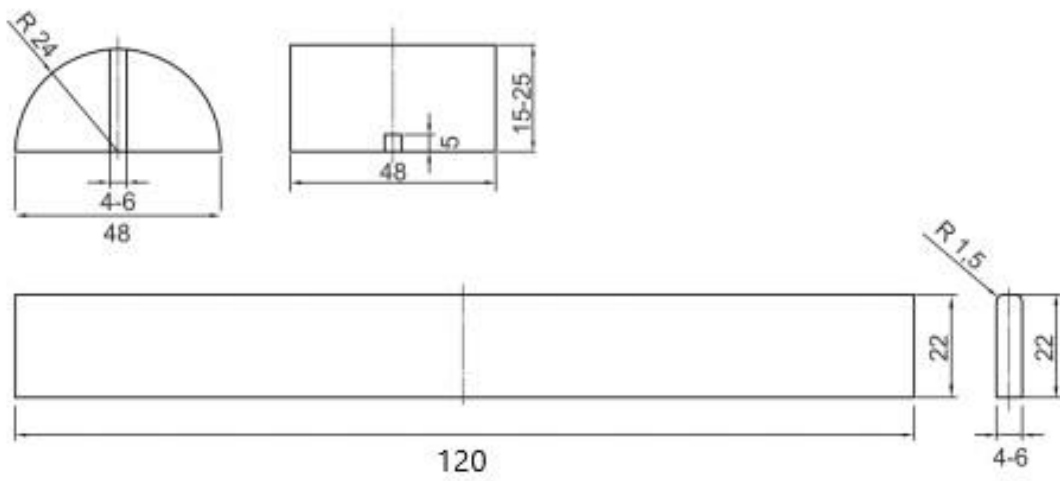

Jamb Board for men and women

